

BHC COMPONENTS

Capacitor Specification

Part Number : ALP20S1009DD

Customer : D.N.M. Design

Customer p/n :

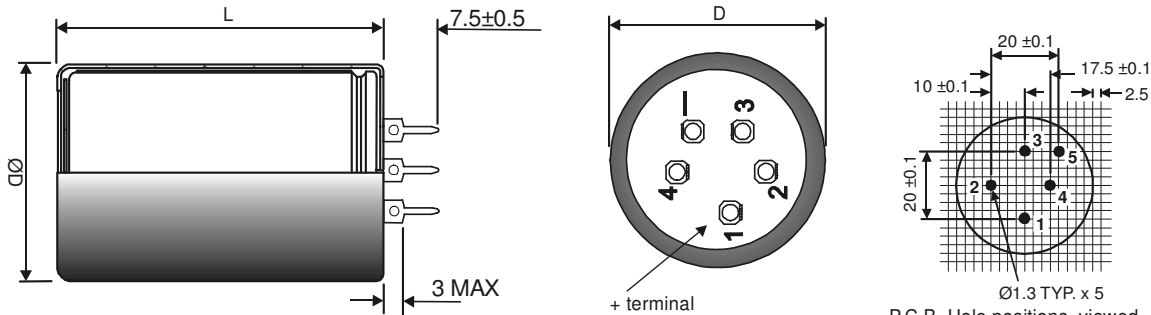

Note: Dummy terminals 2, 3, and 4 may be negative potential due to the presence of electrolyte.

P.C.B. Hole positions, viewed from component side. Hole 5 is -ve.

Diameter (mm) 40 +/-1

Length (L or L2) (mm) 55 +/-2

Terminals 5 Pin

Other Dimensions

Capacitance: 10000 uF

Lower Cap Tolerance: 10 %

Upper Cap Tolerance: 30 %

Working Voltage: 50 V DC

Surge Test Voltage: 57.5 V DC

ESR 40 m'Ohms MAX @ 100 HZ, 20°C

IMPEDANCE 33 m'Ohms MAX @ 10 KHZ, 20°C

DC LEAKAGE 3 mA max @ Test Volts

Test Voltage 50.0V DC

Rated ripple current 5.7 A rms at 100 Hz and 85 °C

Temperature range -40 °C to 85 °C

Approved _____ Date _____

Form : FM003.DES Iss : 2 Date : 10/08/93